

IOT BASED CNG/LPG GAS LEAKAGE ALERT AND MONITORING SYSTEM

Duggirala Asha¹, Kommuri Vasundhara², Payyavula Ganesh³, Mekala Lakshmi Narayana⁴, Koya Nithin Sai⁵

^{2,3,4,5}UG Student,ECE,Chalapathi Institute Of Engineering&Technology Guntur-Andhra Pradesh,India

¹Assistant Professor ECE,Chalapathi Institute Of Engineering&Technology Guntur-Andhra Pradesh,India

Abstract—The rapid growth in the use of liquefied petroleum gas and compressed natural gas in domestic and industrial applications has significantly increased the risk associated with gas leakages. Such leakages can lead to severe hazards including fire accidents, explosions, and health complications. To enhance safety and provide timely intervention, this project presents an IoT based LPG/CNG gas leakage alert and monitoring system designed for continuous monitoring and real time alerting. The proposed system integrates an Arduino Uno microcontroller as the core processing unit, interfaced with a gas sensor to detect the presence of hazardous gas concentrations in the environment. Additionally, a load cell is incorporated to monitor the weight of the gas cylinder, enabling users to track gas consumption and receive early notifications for refilling. The system displays real-time data on an LCD module for on-site monitoring.

Keywords— IoT, LPG Leakage Detection, CNG Gas Monitoring, Arduino Uno, Gas Sensor, Load Cell, GSM module, SMS Alert System, Embedded systems, Safety Monitoring System.

I. INTRODUCTION

In recent years, the widespread use of Liquefied Petroleum Gas (LPG) and Compressed Natural Gas (CNG) has become an integral part of modern living, particularly in domestic kitchens, commercial establishments, and industrial applications. These gases are preferred due to their efficiency, cost-effectiveness, and cleaner combustion compared to traditional fuels. However, despite their advantages, LPG and CNG are highly flammable in nature, and even a minor leakage can lead to catastrophic consequences such as fire outbreaks, explosions, and serious health hazards. This makes gas safety a critical concern that demands reliable and timely monitoring solutions.

Traditional gas detection methods primarily rely on human perception, such as smell or manual inspection, which are often unreliable and delayed. In many cases, gas leaks go unnoticed until they reach dangerous levels, increasing the risk of accidents. Therefore, there is a growing need for an automated system that can continuously monitor gas levels and provide immediate alerts to prevent potential disasters.

With the advancement of embedded systems and the Internet of Things (IoT), it has become possible to design smart monitoring systems that offer real-time detection and remote alert capabilities. IoT enables devices to communicate with users and other systems over networks, ensuring continuous supervision even in the absence of human intervention. By integrating sensors, microcontrollers, and communication modules, such systems can significantly enhance safety and efficiency.

The proposed IoT-based LPG/CNG Gas Leakage Alert and Monitoring System is developed to address these challenges. The system utilizes an Arduino Uno microcontroller to process data from a gas sensor that detects the presence of hazardous gases. Additionally, a load cell is incorporated to monitor the gas cylinder weight, allowing users to track gas consumption and receive early notifications for refilling. The system provides real-time information through an LCD display and ensures immediate response through a buzzer alert during gas leakage.

Furthermore, the integration of a GSM module enables the system to send instant SMS notifications to users, ensuring remote awareness and quick action even when they are not physically present near the system. This combination of local and remote alert mechanisms enhances reliability and minimizes the chances of accidents.

Overall, this project aims to develop a cost-effective, reliable, and user-friendly solution for gas leakage detection and monitoring. By leveraging IoT and embedded system technologies, the proposed system improves safety standards and contributes to the prevention of gas-related hazards in residential, commercial, and industrial environments.

II. REVIEW & LITERATURE SURVEY

The growing concern over gas leakage hazards has led to extensive research in the development of efficient detection and monitoring systems. With the advancement of embedded systems and IoT technologies, several researchers have proposed innovative solutions to enhance safety, reliability, and real-time response in gas leakage detection systems. This section reviews some of the significant contributions in this domain and highlights the evolution of existing technologies.

B. Jena et al. (2023) developed an IoT-based LPG gas leakage detection system that utilizes gas sensors to continuously monitor gas concentration levels. The system is capable of triggering alarms and activating communication modules when leakage is detected. Their work emphasizes the importance of real-time monitoring and immediate response to prevent hazardous situations. However, the system primarily focuses on leakage detection and does not incorporate additional features such as gas level monitoring.

V. Praveen Sharma et al. (2023) presented a comprehensive review of gas leakage detection systems using IoT and cloud technologies. Their study discusses various sensing techniques, communication protocols, and system architectures used in modern detection systems. The authors highlighted the advantages of cloud integration, such as data storage, remote monitoring, and predictive analysis. Despite these benefits, the complexity and cost associated with cloud-based systems can be a limitation for small-scale applications.

Gaddam Poojitha et al. (2025) proposed an Arduino-based gas leakage detection system that detects harmful gases like LPG and methane. The system processes sensor data using a microcontroller and generates alerts when gas concentration exceeds predefined thresholds. This work demonstrates a simple and cost-effective approach suitable for domestic environments. However, it lacks advanced communication features for remote monitoring.

B. F. Alshammari et al. (2020) introduced an IoT-based gas leakage detector integrated with warning generation mechanisms. Their system includes components such as gas sensors, LCD displays, and buzzers to provide real-time alerts. Additionally, it incorporates safety measures like activating exhaust

systems to reduce gas concentration. This approach enhances safety but may require additional hardware, increasing system complexity.

D. Munirathinam et al. (2023) developed a GSM-based gas leakage detection system using Arduino. The system sends SMS notifications to users when leakage is detected, ensuring timely awareness. The integration of GSM technology improves reliability, especially in areas with limited internet connectivity. However, the system focuses mainly on leakage detection and does not address gas consumption monitoring.

The IJRASET Research Community (2022) proposed an advanced system that combines gas leakage detection with gas level monitoring using a load cell. The system displays real-time information on an LCD and sends alerts when gas levels are low or leakage occurs. This integrated approach improves both safety and convenience by addressing multiple aspects of gas management.

From the above survey, it is evident that most existing systems focus primarily on gas leakage detection and alert mechanisms. While some systems incorporate IoT and GSM technologies for remote communication, only a few address comprehensive monitoring, including gas level tracking. Additionally, factors such as cost, complexity, and ease of implementation play a crucial role in determining the practicality of these systems.

The proposed IoT-based LPG/CNG Gas Leakage Alert and Monitoring System builds upon these existing approaches by integrating gas leakage detection, cylinder weight monitoring, real-time display, and GSM-based alert mechanisms into a single, cost-effective solution. This holistic approach enhances safety, improves usability, and provides a more reliable system for both domestic and industrial applications.

III. RESEARCH METHODOLOGY

The development of the IoT-Based LPG/CNG Gas Leakage Alert and Monitoring System follows a structured and systematic approach to ensure accuracy, reliability, and efficiency. The methodology combines both hardware and software design processes, along with testing and validation, to achieve the desired

functionality of real-time gas monitoring and alert generation.

The first stage involves problem identification and requirement analysis, where the risks associated with LPG/CNG gas leakage are studied. Based on this analysis, key requirements such as real-time detection, remote alerting, low cost, and ease of implementation are defined. The system is designed to address both gas leakage detection and gas level monitoring, which are essential for safety and convenience.

In the next phase, system design and architecture are developed. The system is structured around an Arduino Uno microcontroller, which acts as the central processing unit. A gas sensor is selected to detect the concentration of LPG/CNG gases in the environment. A load cell with an amplifier module is integrated to measure the weight of the gas cylinder. Additional components such as an LCD display, GSM module, and buzzer are included to provide user interface and alert mechanisms. The overall system is designed to operate continuously and respond instantly to abnormal conditions.

The hardware implementation phase involves assembling all components as per the circuit design. The gas sensor is connected to the analog input of the Arduino to continuously monitor gas levels. The load cell is interfaced through an HX711 module to measure weight accurately. The LCD display is connected to provide real-time visual feedback, while the buzzer is used for audible alerts. The GSM module is interfaced using serial communication to send SMS notifications to the user during emergencies. Proper power supply regulation is ensured using voltage regulators to maintain stable operation.

Following hardware setup, the software development phase is carried out using the Arduino Integrated Development Environment (IDE). The program is written in embedded C/C++ to read sensor data, process it, and compare it with predefined threshold values. If the gas concentration exceeds the safety limit, the system triggers the buzzer and sends an SMS alert. Similarly, if the cylinder weight falls below a minimum level, a notification is generated for refilling. The LCD continuously displays the gas level and cylinder weight for local monitoring.

The next stage is testing and calibration, where the system is evaluated under different conditions. The gas sensor is calibrated to ensure accurate detection of

leakage levels, and the load cell is calibrated for precise weight measurement. Multiple test scenarios are conducted, including normal conditions, gas leakage situations, and low gas levels, to verify system performance and reliability.

Finally, the validation and analysis phase ensures that the system meets the intended objectives. The results are analyzed in terms of response time, accuracy, and reliability. The system demonstrates effective real-time monitoring and prompt alert generation, making it suitable for practical applications in households and industries.

Thus, the proposed methodology integrates sensing, processing, communication, and alert mechanisms into a cohesive system, ensuring enhanced safety and efficient gas management.

IV. EXISTING SYSTEM

The existing gas leakage detection systems are primarily based on conventional methods and basic sensor technologies that aim to identify the presence of hazardous gases such as LPG and CNG. These systems have been widely used in domestic, commercial, and industrial environments to reduce the risk of accidents caused by gas leaks.

Traditionally, gas leakage detection relied on manual methods, such as human smell detection or periodic inspection of gas pipelines and cylinders. However, these methods are highly unreliable and unsafe, as LPG and CNG gases may not always be easily detectable by smell, especially in enclosed environments. This limitation often results in delayed detection and increases the risk of fire or explosion.

To overcome these drawbacks, several mechanical and chemical detection techniques were introduced, including the use of tracer gases, pressure monitoring, and vapor sensing methods. These techniques are commonly used in industrial applications. For example, methods such as pressure variation analysis, acoustic sensing, and tracer-gas detection are used to identify leaks in pipelines. However, these approaches are often complex, expensive, and not suitable for small-scale or household applications.

Later, sensor-based systems were developed using gas sensors like MQ-series sensors. These systems typically consist of a gas sensor connected to a microcontroller, which detects gas concentration and triggers an alarm when leakage is detected. Many existing systems also include

components such as buzzers, LCD displays, and GSM modules for alert generation. When gas leakage occurs, the sensor sends data to the microcontroller, which processes the signal and activates alarms or sends SMS notifications to users.

Although these systems provide better safety compared to traditional methods, they still have several limitations:

- Most systems focus only on gas leakage detection and do not monitor gas consumption or cylinder level.
- Limited real-time remote monitoring capabilities in basic models
- Dependence on single sensors may reduce accuracy
- Some systems are costly or complex for household implementation
- Lack of integration with IoT platforms for advanced data analysis and automation

Recent advancements have introduced IoT-based systems that improve detection efficiency and enable remote monitoring. However, even these systems may require internet connectivity, cloud infrastructure, or complex configurations, which can increase cost and implementation difficulty.

In summary, existing systems have significantly improved gas safety compared to traditional approaches, but they still lack a comprehensive solution that combines leakage detection, gas level monitoring, real-time alerts, and cost-effectiveness. These limitations highlight the need for an integrated and user-friendly system, which is addressed in the proposed project.

V. PROPOSED METHODOLOGY

The proposed IoT-Based LPG/CNG Gas Leakage Alert and Monitoring System is designed to provide a comprehensive solution for both gas leakage detection and gas level monitoring. Unlike conventional systems, this approach integrates sensing, processing, alerting, and communication mechanisms into a single, efficient framework.

The system is centered around an Arduino Uno microcontroller, which acts as the main control unit. A gas sensor is continuously used to monitor the concentration of LPG/CNG gases in the surrounding environment. The sensor outputs analog signals corresponding to gas levels, which are processed by the microcontroller and compared with predefined safety thresholds. When the gas concentration exceeds the safe limit, the system immediately identifies it as a leakage condition.

In addition to leakage detection, the system incorporates a load cell with an HX711 amplifier module to measure the weight of the gas cylinder. This enables real-time monitoring of gas usage and helps in predicting when the cylinder needs refilling. By integrating this feature, the system not only enhances safety but also improves user convenience.

The system provides dual alert mechanisms for effective response. Locally, a buzzer is activated to give an immediate audible warning when gas leakage or low gas level is detected. For remote alerting, a GSM module is used to send SMS notifications to the user's mobile phone. This ensures that users are informed even when they are away from the location, enabling quick action. A 16x2 LCD display is used to provide real-time information about gas concentration and cylinder weight. This allows users to monitor system status directly. The system operates continuously, collecting and processing data at regular intervals to ensure timely detection and response.

The working of the system can be summarized in the following steps:

1. The gas sensor continuously senses LPG/CNG concentration in the environment.
2. The load cell measures the weight of the gas cylinder.
3. The Arduino processes the sensor data and compares it with predefined threshold values.
4. If gas leakage is detected, the buzzer is activated and an SMS alert is sent via GSM.
5. If the gas level is low, a refill notification is sent to the user.
6. The LCD displays real-time gas level and weight information.

The proposed methodology ensures real-time monitoring, early detection, and rapid alerting, thereby reducing the risk of accidents. It is designed to be cost-effective, easy to implement, and suitable for domestic as well as industrial applications. By combining IoT principles with embedded system design, the system provides an intelligent and reliable solution for gas safety management.

VI. BLOCK DIAGRAM

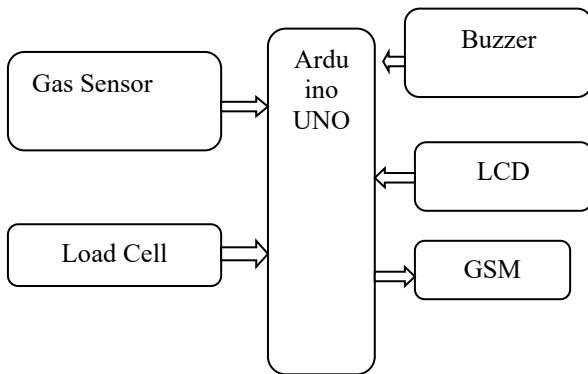

Fig. 6.2. Block Diagram

VII. RESULTS AND OUTCOMES

The implementation of the IoT-Based LPG/CNG Gas Leakage Alert and Monitoring System was successfully carried out, and the system was tested under various real-time conditions to evaluate its performance, accuracy, and reliability. The results obtained demonstrate that the proposed system effectively fulfills its objective of ensuring safety and efficient gas monitoring.

During normal operating conditions, the system continuously monitored both gas concentration and cylinder weight without any interruption. The LCD display provided real-time updates, showing the current gas sensor readings and the weight of the cylinder, enabling users to easily track system status. The readings were found to be stable and consistent, indicating proper calibration of the sensors.

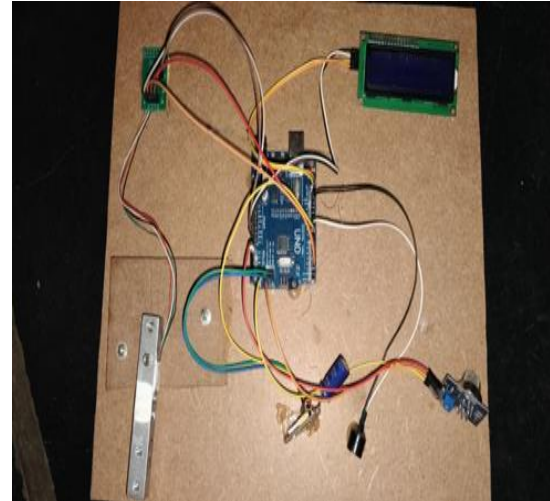

Fig:7.1:Output1

When a gas leakage condition was simulated, the gas sensor detected the increase in gas concentration immediately. Once the predefined threshold was exceeded, the system responded promptly by activating the buzzer alert, providing an instant warning to nearby individuals. At the same time, the GSM module successfully sent SMS notifications to the registered mobile number, ensuring that the user was informed even when away from the location. The response time of the alert mechanism was observed to be minimal, making the system highly effective in emergency situations.

Similarly, when the weight of the gas cylinder dropped below the set limit, the system identified it as a low gas condition. It generated a notification indicating that the cylinder needs refilling. This feature proved useful in preventing sudden gas exhaustion, thereby improving user convenience.

The overall system performance can be summarized as follows:

- Accurate detection of gas leakage with quick response time
- Reliable monitoring of gas cylinder weight using load cell
- Effective dual alert system (buzzer + SMS notification)
- Continuous real-time display of system parameters on LCD
- Stable and consistent operation over extended periods

The outcomes of this project highlight that the system is cost-effective, efficient, and user-friendly, making it suitable for practical deployment in households, commercial kitchens, and small industries. It significantly reduces the risk of accidents

caused by gas leakage and enhances safety through early detection and timely alerts.

In conclusion, the developed system successfully integrates sensing, monitoring, and communication technologies to provide a comprehensive gas safety solution, demonstrating its potential for real-world applications and future enhancements.

VIII.CONCLUSION

The IoT-Based LPG/CNG Gas Leakage Alert and Monitoring System developed in this project provides a reliable and intelligent solution to address the critical safety concerns associated with gas leakage. The system successfully integrates sensing, processing, and communication technologies to ensure continuous monitoring and rapid response in hazardous situations. By combining both leakage detection and gas level monitoring, the system goes beyond traditional solutions and offers a more comprehensive safety mechanism.

One of the major achievements of this project is the implementation of real-time monitoring, which allows continuous observation of gas concentration levels as well as cylinder weight. The system demonstrates high sensitivity in detecting gas leakage and responds immediately when the threshold is exceeded. The integration of a buzzer for local alerts and a GSM module for remote SMS notifications ensures that users are informed instantly, thereby significantly reducing the chances of accidents and enabling timely corrective actions.

Another important aspect of this system is its user-friendly design and cost-effectiveness. The use of readily available components such as Arduino Uno, gas sensors, and GSM modules makes the system affordable and easy to implement. This makes it highly suitable for widespread adoption in households, commercial kitchens, and small-scale industries where safety is a primary concern.

Furthermore, the addition of a load cell for gas level monitoring enhances the practical utility of the system. It not only prevents unexpected gas depletion but also improves overall user convenience by providing early refill notifications. This dual functionality of safety and monitoring makes the system more efficient and valuable compared to existing solutions.

The project also highlights the potential of IoT-based embedded systems in improving everyday safety applications. It demonstrates how simple integration of sensors and

communication modules can create smart systems capable of real-time decision-making and alerting.

However, there is still scope for further improvement. Future enhancements may include integration with mobile applications, cloud-based monitoring, automatic gas shut-off mechanisms, and advanced analytics for predictive maintenance. These improvements can further increase system efficiency, scalability, and user accessibility.

In conclusion, the proposed system successfully achieves its objectives by providing a safe, reliable, and efficient gas monitoring solution. It minimizes risks associated with gas leakage, enhances user awareness, and contributes to the development of smart safety systems. This project serves as a strong foundation for future advancements in IoT-based safety and monitoring technologies.

REFERENCES

1. Vellela, S. S., & Balamanigandan, R. (2024). Optimized clustering routing framework to maintain the optimal energy status in the wsn mobile cloud environment. *Multimedia Tools and Applications*, 83(3), 7919-7938.
2. Vellela, S. S., & Balamanigandan, R. (2023). An intelligent sleep-awake energy management system for wireless sensor network. *Peer-to-Peer Networking and Applications*, 16(6), 2714-2731.
3. Vellela, S. S., & Balamanigandan, R. (2024). An efficient attack detection and prevention approach for secure WSN mobile cloud environment. *Soft Computing*, 28(19), 11279-11293.
4. Vellela, S. S. (2023). Enhanced speckle noise reduction in breast cancer ultrasound imagery using a hybrid deep learning model. *Ingénierie des Systèmes d'Information*.
5. Polasi, P. K., Vellela, S. S., Narayana, J. L., Simon, J., Kapileswar, N., Prabu, R. T., & Rashed, A. N. Z. (2026). Data rates transmission, operation performance speed and figure of merit signature for various quadrature light sources under spectral and thermal effects. *Journal of Optics*, 55(1), 633-643.

6. Praveen, S. P., Nakka, R., Chokka, A., Thatha, V. N., Vellela, S. S., & Sirisha, U. (2023). A novel classification approach for grape leaf disease detection based on different attention deep learning techniques. *International Journal of Advanced Computer Science and Applications (IJACSA)*, 14(6), 2023.
7. Vellela, S. S., Rao, M. V., Mantena, S. V., Reddy, M. J., Vatambeti, R., & Rahman, S. Z. (2024). Evaluation of Tennis Teaching Effect Using Optimized DL Model with Cloud Computing System. *International Journal of Modern Education and Computer Science (IJMECS)*, 16(2), 16-28.
8. Vellela, S. S., & Krishna, A. M. (2020). On Board Artificial Intelligence With Service Aggregation for Edge Computing in Industrial Applications. *Journal of Critical Reviews*, 7(07).
9. Madhuri, A., Jyothi, V. E., Praveen, S. P., Sindhura, S., Srinivas, V. S., & Kumar, D. L. S. (2024). A new multi-level semi-supervised learning approach for network intrusion detection system based on the 'goa'. *Journal of Interconnection Networks*, 24(supp01), 2143047.
10. Raju, V. V. K., Bhavani, Y. V. K. D., Nandikonda, P., Kareemunnisa, F. N. U., Brahmeswara, K. B., & Sindhura, S. (2026). Iterative and Statistical Analytical Review of Predictive Modeling Approaches in Educational Systems: A Comprehensive Benchmark of AI-Driven Methods. *International Journal of Innovative Technology and Interdisciplinary Sciences*, 9(1), 490-522.
11. Biyyapu, N., Veerapaneni, E. J., Surapaneni, P. P., Vellela, S. S., & Vatambeti, R. (2024). Designing a modified feature aggregation model with hybrid sampling techniques for network intrusion detection. *Cluster Computing*, 27(5), 5913-5931.
12. Praveen, S. P., Vellela, S. S., & Balamanigandan, R. (2024). SmartIris ML: harnessing machine learning for enhanced multi-biometric authentication. *Journal of Next Generation Technology (ISSN: 2583-021X)*, 4(1).
13. Vuyyuru, L. R., Purimetla, N. R., Reddy, K. Y., Vellela, S. S., Basha, S. K., & Vatambeti, R. (2025). Advancing automated street crime detection: a drone-based system integrating CNN models and enhanced feature selection techniques. *International Journal of Machine Learning and Cybernetics*, 16(2), 959-981.
14. Vellela, S. S., Roja, D., Purimetla, N. R., Thalakola, S., Vuyyuru, L. R., & Vatambeti, R. (2025). Cyber threat detection in industry 4.0: Leveraging GloVe and self-attention mechanisms in BiLSTM for enhanced intrusion detection. *Computers and Electrical Engineering*, 124, 110368.
15. Vellela, S. S., Pushpalatha, D., Sarathkumar, G., Kavitha, C. H., & Harshithkumar, D. (2023). Advanced intelligence health insurance cost prediction using random forest. *ZKG International*, 8.
16. Vellela, S. S., Babu, B. V., & Mahendra, Y. B. (2024). IoT-based tank water monitoring systems: enhancing efficiency and sustainability. *International Journal for Modern Trends in Science and Technology*, 10(02), 291-298.
17. Vellela, S. S., Varshini, K., Jeevana, M., Kadheer, S. K., & Kumar, T. P. (2024). IoT based smart irrigation and controlling system. *IoT Based Smart Irrigation and Controlling System*, *International Journal for Modern Trends in Science and Technology*, 10(02), 77-85.
18. Vellela, S. S., Chaganti, A., Gadde, S., Bachina, P., & Karre, R. (2022). A Novel Approach for Detecting Automated Spammers in Twitter. *Mukt Shabd*, 11, 49-53.
19. Vellela, S. S., Narapasetty, S., Somepalli, M., Merikapudi, V., & Pathuri, S. (2022). Fake News Articles Classifying Using Natural Language Processing to Identify in-article Attribution as a Supervised Learning Estimator. *Mukt Shabd Journal*, 11.
20. Vellela, S. S., Vineeth, S., & Suresh, V. (2024). IoT Based ICU Patient Monitoring System. *IoT Based ICU Patient Monitoring System*,

- International Journal for Modern Trends in Science and Technology, 10(02), 265-273.
21. Vellela, S. S., & Balamanigandan, R. (2025). Designing a Dynamic News App Using Python. Available at SSRN 5250912.
 22. Vellela, S. S., Rao, M. V., Krishna, C. V. M., Rao, T. S., & Dasthavejula, R. (2026). Piezoelectric and Shape-Memory Materials for Actuators and Energy Harvesting in Mechanical, Electronics, and Biomedical Engineering Using AI-Based Design. In *Advanced Materials for Biomedical Devices* (pp. 195-206). CRC Press.
 23. Vellela, S. S., Singu, K., Kakarla, L. S., Tadikonda, P., & Sattenapalli, S. N. R. (2025). NLP-Driven Summarization: Efficient Extraction of Key Information from Legal and Financial Documents. Available at SSRN 5250908.
 24. Vellela, S. S., Anusha, P., Vullam, N. R., Jala, J., Bellapu, V. S., & Vindhya, A. S. (2025, October). Quantum Cryptography and Key Distribution for Secure Communication in the Post Quantum World. In *2025 International Conference on Sustainable Communication Networks and Application (ICSCN)* (pp. 619-624). IEEE.
 25. Roja, D., Jidugu, S. K., Rao, T. S., Vuyyuru, L. R., Vellela, S. S., & Ranjani, B. S. (2025, December). High-Fidelity Image Synthesis using Enhanced Generative Adversarial Networks with Attention Mechanisms. In *2025 International Conference on NexGen Networks and Cybernetics (IC2NC)* (pp. 885-890). IEEE.
 26. Vellela, S. S., Vuyyuru, L. R., Jidugu, S. K., Rao, M. P., & Srinivas, B. R. (2025, November). The Impact Of Quantum Computing On Blockchain Security And Quantum Resistant Protocols. In *2025 2nd International Conference on Intelligent Systems for Cybersecurity (ISCS)* (pp. 1-6). IEEE.
 27. Yanamadala, N., & Vellela, S. S. (2025, June). Ensuring Authenticity and Confidentiality in Images using SHA-ECC Fusion. In *2025 Second International Conference on Networks and Soft Computing (ICNSoC)* (pp. 684-689). IEEE.
 28. Vellela, S. S. (2024). A Comprehensive Review of AI Techniques in Serious Games: Decision Making and Machine Learning.
 29. Burra, R. S., APCV, G. R., & Vellela, S. S. (2024). Strategic Insights: Unleashing the Power of Big Data Analytics for Credit Investigation and Risk Mitigation in Commercial Banking. *International Journal of Progressive Research in Engineering Management and Science*, 4(01), 458-464.
 30. Vellela, S. S., Purimetla, N. R., Vindhya, A. S., Vullam, N. R., Srinivas, B. R., & Vuyyuru, L. R. (2025, October). Design and Simulation of Quantum Error Correction Codes for Scalable Quantum Architectures. In *2025 7th International Conference on Innovative Data Communication Technologies and Application (ICIDCA)* (pp. 1570-1575). IEEE.
 31. Vellela, S. S., Purimetla, N. R., Rao, P. V., Daniel, V. A. A., Koppolu, H. K. R., & Janani, B. (2025). AI-Enabled Wearable Hemodynamic Monitoring System for Early Identification of Thrombotic Events. *Vascular and Endovascular Review*, 8(16s), 321-336.
 32. Venkatesh, N., Maheswari, S., & Triveni, P. (2024). Harnessing IoT for Real-Time Plant Health Monitoring: Challenges and Opportunities.
 33. Reddy, B. V., Kumar, A. H., Gopi, C., Prasad, Y. V. D., Vellela, S. S., & Roja, D. (2025, April). Machine learning based automated liver fibrosis stage diagnosis with prediction. In *2025 International Conference on Advances in Modern Age Technologies for Health and Engineering Science (AMATHE)* (pp. 1-6). IEEE.
 34. Rao, M. V., Sreeraman, Y., Mantena, S. V., Gundu, V., Roja, D., & Vatambeti, R. (2024). Brinjal Crop yield prediction using Shuffled shepherd optimization algorithm based ACNN-OBDSLSTM model in Smart Agriculture. *Journal of Integrated Science and Technology*, 12(1), 710-710.

35. Haritha, K., Geethika, N. S., Venkateswarlu, K., Kumar, R. H., & Ramakrishna, Y. Enhancing Public Safety with AI & ML-Based CCTV Surveillance.
36. Haritha, K., Prakash, P. B., Pravallika, D., Venkatesh, K., & Venkatesh, G. Enhancing Object Detection in Autonomous Vehicles Under Low-Light Conditions Using Federated Learning and YOLOv5.
37. Ram, C. S., Vellela, S. S., Sravanthi Javvadi, D. V., Rashid, S. Z., & Madhumathi, S. M. (2025). Integrated Robotic-Imaging Platforms in Endovascular Surgery: Current Capabilities and Future Directions. *Vascular and Endovascular Review*, 8(16s), 285-298.
38. Roja, D., Navya, G., Srujana, B. S., Mamatha, P., & Sai, C. Y. K. Deep Learning for Hotel Reviews: A Framework for Sentiment Classification and Fake Review Detection.
39. Pakalapati, S., Rani, C. J., Vellela, S. S., Thanuja, N., & Bindu, M. N. H. (2025, November). Progressive GAN-based Framework for Realistic Image Generation and Style Transfer. In 2025 5th International Conference on Evolutionary Computing and Mobile Sustainable Networks (ICECMSN) (pp. 474-479). IEEE.
40. Balamanigandan, R., Vellela, S. S., Gorintla, S., Vuyyuru, L. R., Thanuja, N., & Rao, T. S. (2025, September). Quantum-Enhanced Data Security for Electronic Health Records: A Framework for Post-Quantum Cryptography in Healthcare Systems. In 2025 6th International Conference on Smart Electronics and Communication (ICOSEC) (pp. 1924-1929). IEEE.
41. Roja, D., Amulya, P., Nagasai, M., Prasad, D. D., & Babu, A. V. Machine Learning-Based Early Diagnosis of Fish Diseases via Water Quality Data.
42. Sai, M. B., & Vellela, S. S. (2025, December). Hybrid ML Driven Multi-Cloud Service Work Load Prediction For Financial Systems. In 2025 1st International Conference on Advancement in Futuristic Technologies (ICAFT) (pp. 1-6). IEEE.
43. Kareemunnisa, D., Haritha, K., Ranjani, B. S., Venkateswarlu, K., & Bindu, M. N. H. DUAL-STAGE PRIVACY PROTECTION FOR GRAPH NEURAL NETWORKS AGAINST INFERENCE ATTACKS.
44. Mandava, R., Haritha, K., Vellela, S. S., Purimetla, N. R., Mohan, B. K., & Harinadh, T. (2025, June). Analysing User Perceptions of Trust in Financial Systems Using Explainable AI. In 2025 Second International Conference on Networks and Soft Computing (ICNSoC) (pp. 26-30). IEEE.